

## DESIGN AND IMPLEMENTATION OF IOT-BASED 1000VA POWER INVERTER SYSTEM

Ejimofo I.A.<sup>1</sup>, Ebih U.J.<sup>2</sup>, Nwanze D. E.<sup>3</sup>

1: Dept. of Computer Engineering, Madonna University of Nigeria, Akpugo Campus, Enugu State, Nigeria.

2: Dept. of Electronic and Computer Engineering, Nnamdi Azikiwe University, Awka, Nigeria.

3: Dept. of Computer Science, Novena University, Ogume, Delta State, Nigeria.

### ABSTRACT

This paper presents the design and implementation of 1000VA Inverter System with Internet of Things (IoT) that helps to ameliorate the impact of the excruciating economic hardship, especially on Small and Medium Scale Enterprises (SMEs) that largely depends on electricity for survival amidst energy crises, scarcity and rise in premium motor spirit price in Nigeria. The inverter system was designed using two microcontrollers, ATMEGA328P and NodeMCU. The ATMEGA328P is responsible for the generation of the sine pulse width modulation (SPWM), control and stability operation; while connection for wireless monitoring and control is carried out by NodeMCU. The features of the inverter pure sine wave output, stable output voltage of  $220V \pm 2.36\%$  and output frequency of  $50Hz \pm 0.3\%$  were obtained from the tests carried out on the system. The inverter system has short-circuit protection, overload protection, state of charge battery monitoring and protection, automatic changeover as well as monitoring and control using connected mobile devices and computer system. The inverter designed and built is scalable as the capacity can be increased to the load demand of the user, and thus it is suitable for industrial, commercial and residential use.

**Keywords/Phrases:** Inverter, Internet of Things, Pure Sinewave, Alternative Energy, Microcontroller.

### I. INTRODUCTION

Nigeria, just like other countries of the world, is still engulfed with energy challenges. This is heightened by energy crises witnessed across the globe. The energy sector of this country, Nigeria, is not an exception, as there had been consistent collapse of national grid amidst scarcity of premium motor spirit and rise in its price. This has forced many Small and Medium

Scale Enterprises (SMEs) to permanently shut down.

The Federal Government of Nigeria had tried to provide different policies to regulate the power sector for efficient power supply but due to some fundamental factors the expectation is far from been reached. This had impact on the economy of the nation as national grid were put on load shedding while cutting supplies to many states and cities (Oladipo, 2022). This is an indication that the problem of poor electricity supply in Nigeria is still persistent and requires keen attention as nation cannot develop economically without electricity supply. Idowu (2020) opined that lack of adequate power supply is one of the factors killing small and medium scale enterprise (SMEs) in Nigeria, hampering viable economic growth in the country.

One of the major means of providing alternative source of electricity is the use of power inverter system. A power inverter system is an electrical device that changes direct current (DC) electricity to alternating current (AC) electricity (Akinyele *et al.*, 2015), useful for AC appliances at the required voltage and frequency. Basically, power inverter system takes input power from direct current (DC) sources such as flywheels, batteries, or super capacitors, and inverts the DC input into an alternating current (AC) output which can be used to power electrical and electronic equipment.

With the development in technology and production of solar panel, capable of converting solar energy into DC electricity that can be used directly or stored in batteries, power inverter system can be used as a standalone power supply for residential, commercial and industrial applications. Musa and Galadanci, (2019) opined that due to the reliability of inverter system, it is used as protective devices for hardware, such as server for data centre, In vitro fertilization (IVF) machine etc., which can

cause serious damage or loss as a result of sudden power disruption.

In this research, Internet of Things (IoT) was incorporated into the power inverter system to give more data on the operation of the power inverter system, improve monitoring and self-protection. With IoT capability, the system monitors different faults and communicate with the user on the real time operation of the equipment. This enable ease of use, management and maintenance as operation data are available for the user as well as maintenance personnel. With IoT, user can power ON/OFF the inverter system wirelessly, remotely monitor the operation of the system as well as identify cause of any fault if it is about to occur or had occurred. This designed and constructed inverter system is powered by lithium-ion battery which had various advantages over lead-acid battery. Advantages of lithium-ion battery over lead acid battery include but not limited to higher efficiency, light weight, maintenance free, longer lifespan, high energy density, higher depth of discharge etc. (Clean Energy Review, 2020; Unbound Solar, 2020; Flash Battery 2022).

Apart from the functionality of this inverter system, the use of lithium-ion battery, incorporation of maximum power tracking circuit and IoT capability makes the inverter more efficient, all-in-one and ease of usage for users.

## II. LITERATURE SURVEY

### 2.1 Some Related Literatures

Clarke (2022) proposed an IoT-based energy management system for DC microgrids that functions by employing an

energy supporting and consumption strategy based on a priority list. During power generation, the main priority is to support the energy demand from the microgrid by the photovoltaic cells. In this manner the photovoltaic cells reach their Maximum Power Point Tracker (MPPT) power, then the system shifts priority to support the loads if the demand of the micro-grid is higher than the photovoltaic cells and interlinking circuit.

Akinyele et al. (2015) carried out research on a distributed cooperative IoT system to solve problems they identified in flood disaster prevention such as high network load and latency of feedback control in server-centric IoT system, and proposed a Distributed Cooperative IoT System for flood disaster prevention.

Britannica (2020) carried out research on a cloud and android based home automation system that could be used, among other things to control and monitor appliances in a home. The system is organized in a way which allows for multiple users to control appliances through an android application and a web application.

## III. SYSTEM DESIGN METHODOLOGY

This research was aimed at designing and implementing 1000VA power inverter system with Internet of Things (IoT) capability. In order to achieve this aim, the researcher adopted block diagram, circuit diagram and system architecture as its design methodology. The block diagram of the power inverter is shown in Figure 1.

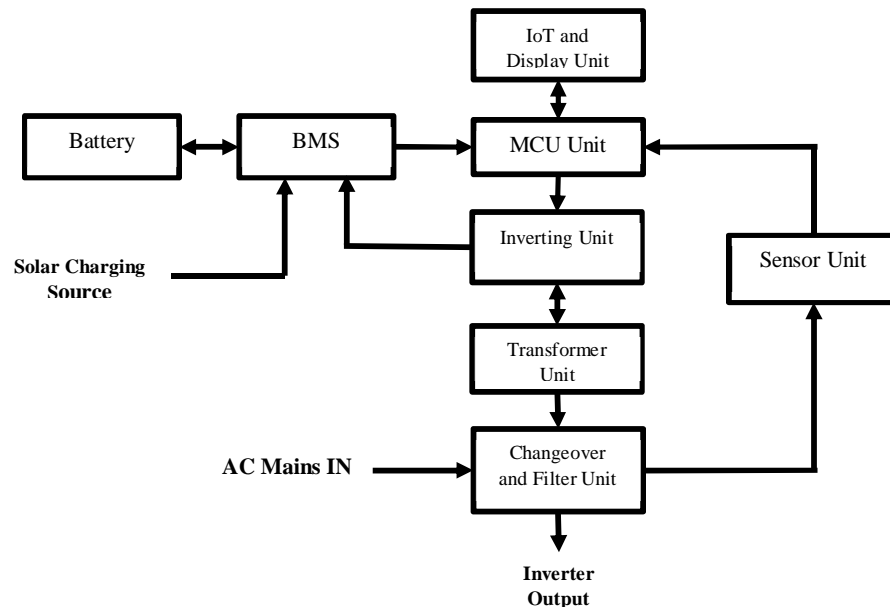

Figure 1: Block Diagram of a Power Inverter System

### 3.1 IoT and Display Unit

The IoT of the inverter is powered by NodeMCU while the display was made using 16x2 alphanumeric Liquid Crystal Display (LCD). NodeMCU is an open source IoT platform. It includes firmware which runs on the ESP8266WiFi SoC from Espressif, and hardware which is based on the ESP-12 module. NodeMCU firmware uses the Lua scripting language. It is based on the eLua project, and built on the Espressif Non-OS SDK for ESP8266. The ESP8266 is a Wi-Fi SoC integrated with a Tensilica Xtensa LX106 core, widely used in IoT applications (Etuk 2020).

NodeMCU handles communication between the users' devices such as smartphone, laptops and other mobile devices using Wi-Fi wireless technology. NodeMCU also interfaces with the main microcontroller using serial communication protocol (Universal Asynchronous Receiver/Transmitter- UART). The data received from the users via their connected devices and that which is received from the main microcontroller is displayed on the screen. Figure 2 shows the picture of NodeMCU and LCD on test table.



Figure 2: NodeMCU and LCD Display

### 3.2 Battery

The battery that is used in this design is lithium-ion battery. A lithium-ion battery is a family of rechargeable battery types in which lithium ions move from the negative electrode to the positive electrode during discharge and back when charging. Lithium-ion batteries use an intercalated lithium compound as the electrode material instead of metallic lithium (Idowu 2020). The lithium-ion were arranged in series and parallel connection known as pack to generate the 24V required by the power inverter system. This is shown in Figure 3.

### 3.3 Battery Management System (BMS)

A battery management system (BMS) is electronic circuit which manages rechargeable battery cell by monitoring the battery state of charge, protection the battery against overcurrent/short-circuit, temperature and other undesirable conditions. Battery management system ensure that battery cells are operated

within their safe operating region. In this design, the battery management system was designed using a microcontroller which monitors each battery cell other operation required of a battery management system. The circuit board of the battery management system is shown in Figure 4.



**Figure 3: Lithium-Ion Battery Pack**

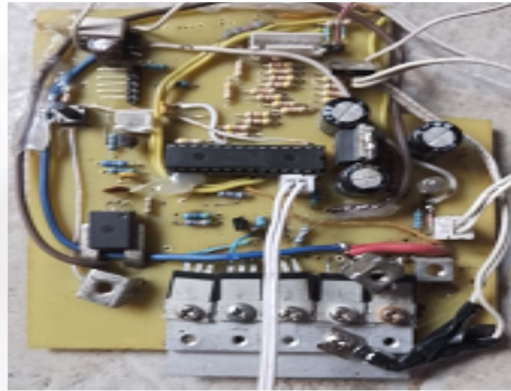

**Figure 4: BMS Circuit Board**

**3.4 Microcontroller Unit**

The main microcontroller unit in this research was ATMEGA328P. This microcontroller is responsible for monitoring and control of the entire power inverter system as well as generation of sine pulse width modulation (SPWM).

The carrier frequency of the SPWM is 20kHz. Since the microcontroller operates with 16MHz clock frequency, the number of switching to generate pure sinew wave at 50Hz is calculated using Equation 1.

$$\begin{aligned} \text{Number of switching} &= \frac{\text{carrier frequency}}{\text{fundamental frequency}} \dots\dots\dots(1) \\ &= \frac{16000}{50} = 320 \end{aligned}$$

Using Equation 2, sine lookup table was generated. This sine lookup table governs the duty cycle of the SPWM to maintain the output voltage at 220V, using feedback sensor, at the required 50Hz frequency.

$$\begin{aligned} \text{Table value} &= \sin\left(\frac{180^\circ}{\text{switching number}}\right) \\ &\times \text{Step number} \\ &\times \text{maximum Duty cycle} \dots\dots (2) \end{aligned}$$

Generation of SPWM was carried out using TIMER1 of the microcontroller configured on fast pulse width module (FPWM) mode. The program on the microcontroller was written using C programming language on Visual Studio Code (VS Code) IDE.

The microcontroller has two interrupt pins and these pins were configured to detect short-circuit at the output of the inverter and when public power supply from the national grid is available or not. When short-circuit occurs, pin 4 (interrupt pin) of the microcontroller is pulled to 5V, triggering shutdown of the system to prevent damage to the unit.

When there is grid supply, pin 5 (interrupt pin) of the microcontroller is pulled to 0V, thus, the microcontroller automatically changes over the output from the inverter to the national grid, as well as trigger the charging of the battery. Immediately the grid supply goes, the interrupt on the pin is triggered by pulling the pin to 5V, enabling the microcontroller to change the grid supply to the inverter supply, maintaining constant supply to the connected load. The picture of the microcontroller circuit board is shown in Figure 5.



**Figure 5: Circuit Board for the Microcontroller Unit**

Other functions carried out by the microcontroller are the monitoring of the output voltage, using negative feedback mechanism, system temperature monitoring and system over-load monitoring.

**3.5 Inverting Unit**

The inverting unit is situated between the microcontroller and the transformer. It is responsible for changing the DC input from Battery into AC which is feed to the transformer for step-up to a voltage useable by appliance (220V AC).

The inverting unit is made up of MOSFET and MOSFET drive. The MOSFET used in this design was IRF3205. The choice of the MOSFET was based on its ruggedness, cheap, voltage and current capability as well as the drain-to-source resistance. The MOSFET was configure on full bridge and the number of MOSFET per arm of the bridge was determined using Equations (3) to (9).

$$\begin{aligned}
 & \text{Active Power (in Watt)} \\
 & = \text{Reactive Power (in VA)} \\
 & \times \text{power factor (cos}\phi\text{)} \dots\dots (3)
 \end{aligned}$$

The reactive power of the inverter is 1000VA and the power factor for the design is 0.95, hence the active power of the system is given as

$$\begin{aligned}
 \text{Active Power} & = 1000 * 0.9 \\
 & = 950W \dots\dots (4)
 \end{aligned}$$

The maximum current to flow through the MOSFET is given as

$$\begin{aligned}
 \text{Current} & = \frac{\text{Power}}{\text{Voltage}} = \frac{950}{24} = 39.58A \\
 & \approx 40A \dots\dots (5)
 \end{aligned}$$

The power dissipated while carrying a load of 40A by the MOSFET is a function of the drain-to-source resistance and can be calculated as

$$\begin{aligned}
 & \text{Power dissipation} \\
 & = \text{Current}^2 \\
 & \times \text{Resistance} \dots\dots (6)
 \end{aligned}$$

IRF3205 has drain to source resistance ( $R_{DS}$ ) of  $8m\Omega$ . Targeting maximum power dissipation of 6W on the MOSFET, the effective resistance will be

$$\begin{aligned}
 \text{Resistance} & = \frac{6}{40^2} = 0.00375\Omega \\
 & \approx 4m\Omega \dots\dots (7)
 \end{aligned}$$

Let the number of MOSFETs to give effective resistance ( $R_E$ ) of  $4m\Omega$  to be n, hence

$$\frac{1}{R_E} = n \left( \frac{1}{R_{DS}} \right) \dots\dots\dots (8)$$

$$\therefore n = \frac{R_{DS}}{R_E} = \frac{8}{4} = 2 \text{ MOSFETs} \dots\dots (9)$$

Hence, for each of the arm of the full bridge network, two (2) MOSFETs were paralleled to provide the desired power for the inverter.

The MOSFET driver used in this design was IR21010 MOSFET driver. The IR2110 is a high and low-side IGBT and MOSFET gate driver IC that can provide isolation up to 500V with source and sink current capability of up to 2.5A (Oladipo 2022). The signal for the switching of the MOSFET is generated by the microcontroller, which IR2110 uses to switch the MOSFET for inverting operation and production of pure sinewave electricity. The circuit board of the inverting unit with filter and changeover is shown in Figure 6.



**Figure 6: Inverting Unit Circuit Board with Changeover and Filter Circuit**

**3.6 Transformer Unit**

In electrical power system, the device that transfers electric energy from one alternating current (AC) circuit to one or more other alternating current circuits, either increasing (stepping up) or decreasing (stepping down) voltage and corresponding current while maintaining the electrical power is called transformer (Britannica, 2020). Transformer works using the principle of electromagnetic induction.

The transformer is used to step the generated 24V AC from the full bridge network to 220V AC to power electrical gadgets. Hence, the transformer used is a step-up transformer. The turn ratio of the transformer was calculated using Equations (10) to (13).

$$\frac{\text{Primary turn } (N_1)}{\text{Secondary turn } (N_2)} = \frac{\text{Primary Voltage } (V_1)}{\text{Secondary Voltage } (V_2)} \dots \dots (10)$$

The primary and secondary voltages are 24V and 220V respectively while the secondary turn was chosen to be 110 turns, hence the primary winding becomes

$$N_1 = \frac{24 \times 110}{220} \text{ 12 turns } \dots \dots (11)$$

The maximum current on the secondary side is given as

$$\text{Max. Sec. Current} = \frac{\text{Power}}{\text{Voltage}} = \frac{1200}{220} = 5.45A \dots \dots (12)$$

The wire gauge selected for the secondary to be able to carry such current was 14 (1.6mm copper cable)

For the primary winding,

$$\text{Max. Pri. Current} = \frac{\text{Power}}{\text{Voltage}} = \frac{1200}{24} = 50A \dots \dots (13)$$

The wire gauge selected for the secondary to be able to carry such current was 1 AWG (7.3mm copper cable).

**3.7 Changeover and Filter Unit**

To Filter out the high frequency generated by the microcontroller (16MHz) and allow only 50Hz to pass, a Low Pass Filter was used. A Low Pass Filter is a circuit that can be designed to modify, reshape or reject all unwanted high frequencies of an electrical signal and accept or pass only those signals wanted by the circuit designer. The low pass filter used for resistor-capacitor filter circuit. The formula to calculate the required resistor and capacitor for the low pass filter is given as:

$$F = \frac{1}{2\pi RC} \dots \dots \dots (14)$$

The desired frequency (F) is 50Hz, a resistor (R) of 1500Ω was chosen, hence, the value of the capacitor (C) is calculated as

$$C = \frac{1}{2 \times \frac{22}{7} \times 1500 \times 50} = 2.12 \times 10^{-6} = 2.12\mu F \dots \dots \dots (15)$$

A commercially available 2.2μF was used for the work.

For changeover operation, two 12V20A relays were used to connect or disconnect the live and neutral of the load to the inverter output when there is no grid supply and when there is grid supply respectively.

**3.8 Sensor Unit**

The Sensor unit is used to provide feedback to the microcontroller and thus be able to carry out control function. Sensor unit has current and voltage sensor to determine load connected to the inverter, thus monitor overload and shortcut, mains AC supply sensor to be able to

determine when mains supply is available or not and this be able to changeover between the inverter output and AC mains supply.

The current sensing was carried out using ACS758ECB-100B-PFF-T. ACS758ECB-100B-PFF-T is a current sensing chip produced by Allegro which uses hall effect to sense current. Applied current flowing through this copper conduction path generates a magnetic field which the Hall IC converts into a proportional voltage. ACS758ECB-100B-PFF-T has sensitivity of 20mV per Amp, thus the current drawn by the load was calculated using Equation (16).

The AC grid supply was sensed using PC817 optocoupler IC. The optocoupler pulls the

interrupt pin of the microcontroller low when there is grid supply while the interrupt pin is pulled high when grid is not available. Using the interrupt routine of the microcontroller, the system could automatically changeover from grid supply to the inverter supply, providing constant output to the connected load. Figure 7 depicts the picture of the current sensor while Figure 8 shows the PC817 optocoupler output pin configuration.

$$\begin{aligned} LoadCurrent &= \frac{analogRead \times 5}{0.02 \times 1023} \\ &= analogRead \\ &\times 0.2443792766373412 \dots \dots (16) \end{aligned}$$

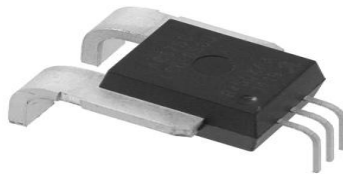

Figure 7: ACS758ECB-100B-PFF-T

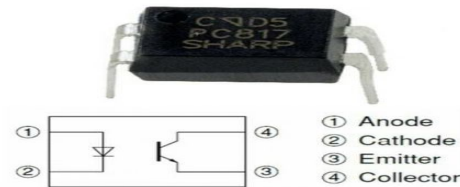

Figure 8: PC817 Optocoupler

#### IV. TESTING AND RESULTS

##### 4.1 Inverter Output Waveform

The inverter system was designed to generate a sine wave at the output which is a replica of what is generated by the national grid and required to power appliances especially load with inductive characteristics. The output of the inverter was connected to oscilloscope and a pure sinewave curve was seen as the output waveform of the inverter as shown in Figure 9.

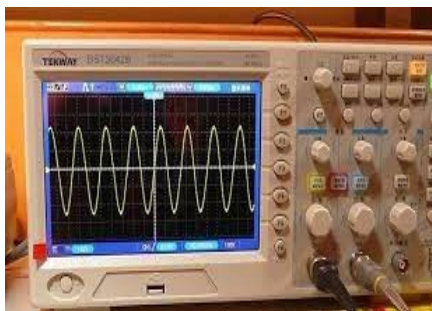

Figure 9: Inverter System Output Waveform

### 4.2 Output Parameter Stability (Voltage and Frequency)

The stability of the output voltage over different load range as well as the frequency were tested

so ensure that the system output voltage is within acceptable limit. Table 1 shows the result of the output voltage and frequency verses load.

Table 1: System Output Stability Test Results

S/No	Load (Watt)	Output Voltage(V)	Frequency (Hz)
1	0	225.2	50.15
2	100	222.5	50.12
3	200	223.3	50.10
4	400	221.7	50.01
5	600	219.1	49.99
6	800	218.5	49.95
7	900	217.5	49.93

From the results of Table 1, Equation (17) was used to determine the deviation from the designed value for both voltage and frequency.

$$\text{Deviation} = \frac{\text{Output Value} - \text{Designed Value}}{\text{Designed Value}} \times \frac{100}{1} \dots\dots\dots (17)$$

- i. maximum voltage upward deviation from the designed 220V AC is  $\frac{225.2 - 220}{220} \times \frac{100}{1} = 2.36\%$
- ii. maximum voltage downward deviation from the designed 220V AC is

- iii. maximum frequency upward deviation from the designed 50Hz AC is  $\frac{50.15 - 50}{50} \times \frac{100}{1} = 0.3\%$
- iv. maximum frequency downward deviation from the designed 50Hz AC is  $\frac{49.93 - 50}{50} \times \frac{100}{1} = -0.14\%$

From the results and analysis carried out, the 100VA inverter system designed has output voltage of 220V±2.36% and output frequency of 50Hz±0.3%.



Figure 10: Output Frequency



Figure 11: Output AC Voltage

### 4.3 IoT Performance Test

The Internet of Things capability of the system was tested to ensure that it worked as designed. The system uses Wi-Fi for communication and this connection to the system was established by putting the system Wi-Fi password. The

interface for the interaction with the system using connected mobile phone or laptop is shown in Figure 12.

From the interface, the system can be powered ON or OFF using the system control button on the interface. The load connected, charging and



discharging status, battery percentage as well as type of fault that happened on the system, if there is any and the number of times faults had occurred before.

Figure 13 shows the arrangement of the circuit boards in a rectangular casing used to house the work.

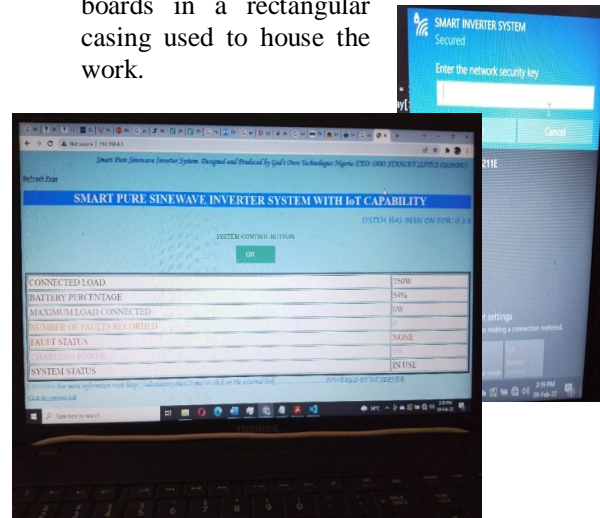

**Figure 12: Connection and Control of the Inverter System using IoT Technology**

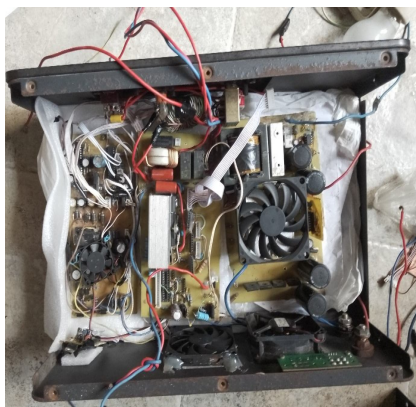

**Figure 13: Interior Arrangement of Circuit Boards for the Inverter System in a Casing**

## V. CONCLUSION AND RECOMMENDATION

### 5.1 Conclusion

A pure sine wave inverter system with high output stability had been designed and implemented using ATMEGA328P microcontroller and NodeMCU IoT chip. The inverter system has many features such as output voltage and frequency stability, overload cut off capacity, short-circuit protection, automatic changeover, ensuring constant power supply to the connected load and Internet of Things capability. ATMEGA328P is responsible for the generation of the sine pulse width modulation (SPWM), control and

stability operation while connection for wireless monitoring and control is carried out by NodeMCU.

With this inverter system, the problem of unstable power supply in Nigeria can be ameliorated and confidence on the use of inverter system to provide alternative source of energy is increased as the system has protective feature to prevent the system from incessant damage, which is associated with previous inverter system designed.

### 5.2 Recommendation

Since the designed and constructed inverter system is rugged and reliable for providing power to commercial and residential loads, inductive, resistive and capacitive, it is recommended that businesses, establishments as well as private individuals should make use of inverter system, as this will help boost the economy as well as reduce reliance on national grid.

## REFERENCES

- Akinyele Oluwaseun, D.O. Aremu, Ogunlowo Qazem A.A. Azeez, Babajide Nathaniel, Clement Ogunlade, A.C. Alaka (2015), "Construction and Evaluation of a Power Inverter", 10.13140/RG.2.2.25836.00642.
- Britannica Edwin (2020), 'Transformer', Accessed from

- <https://www.britannica.com/technology/transformer-electronics> on 10<sup>th</sup> February, 2022.
- Etuk Bonye (2020), “Lead-Acid Vs Lithium-Ion Batteries”, Retrieved from <https://www.cleanenergyreviews.info/blog/simpliphi-pylontech-narada-bae-lead-acid-battery> on 15th February, 2022.
- Clarke Louis (2022), “Why Change from a Lead-Acid Battery to a Lithium Battery?”, Retrieved from <https://www.flashbattery.tech/en/why-switch-from-lead-acid-battery-to-lithium-battery/> on 11<sup>th</sup> January, 2022.
- Idowu Y. (2020), “Design and Construction of a 1KVA Power Inverter”, Unpublished B.Tech Thesis, LAUTECH, Ogbomoso, Pps.12-35.
- Musa A., Galadanci G.S.M. (2021), “5KVA Power Inverter Design and Simulation Based on Boost Converter and H-bridge Inverter Topology”, Bayero Journal of Pure and Applied Sciences (BAJOPAS), 2(1): 6 - 13
- Oladipo O. (2022), “National Grid Collapsed for the First Time in 2022”, Publication of Business Day Newspaper, Accessed from <https://businessday.ng/energy/power/article/national-grid-collapses-for-the-first-time-in-2022/> on 7th February, 2022.
- Qiao H., Wei Q. (2012), “Functional Nanofibers and their Applications”, A Volume in Woodhead Publishing Series in Textiles, Pps.4-13.